

MOULDED CABINET LOUDSPEAKERS

PWC6T/EN

PWC6T/ENC



INSTALLATION INSTRUCTIONS

EN54-24:2008

Certificate No: 0359-CPD-0167 Type A

1. LOUDSPEAKER ENCLOSURE
2. REFERENCE AXIS
3. REFERENCE PLANE
4. HORIZONTAL PLANE

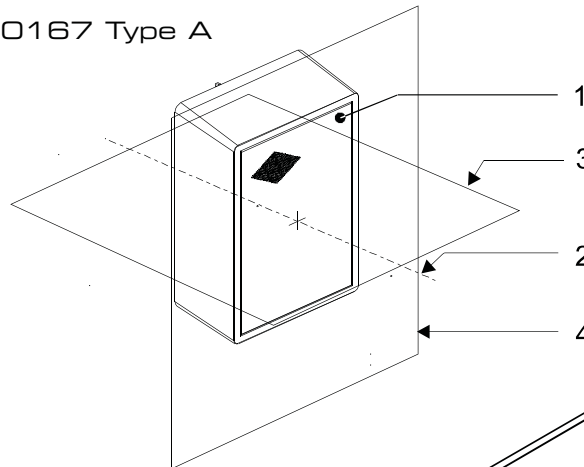

Circuit Diagram

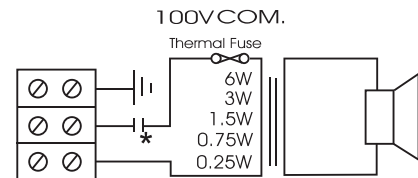

- ▶ PWC6T/EN
- ▶ PBW6T/ENC
- * with capacitor

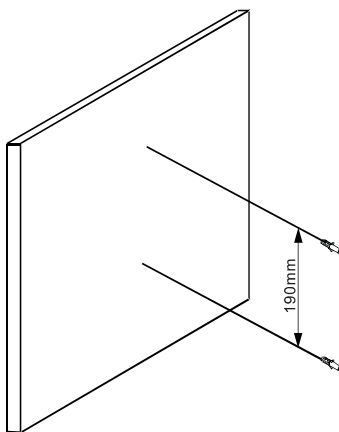

1. Remove the front grill from the speaker by using a flat blade or screw driver placed between the grill and case. Gently lever the grill upwards taking care not to damage the grill or plastic cabinet.

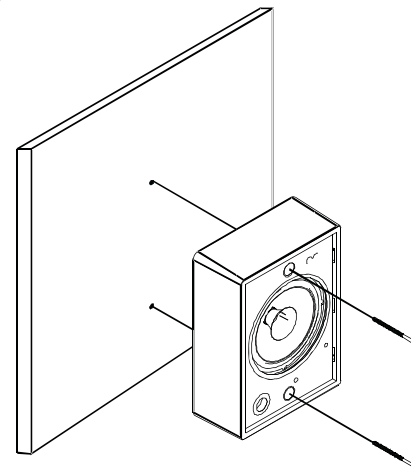

2. Once the grill has been removed place the speaker on a flat surface in your chosen position. Mark the fixing points on the wall. Prepare the wall to take the fixings. If 20mm cable glands are to be used then the speaker cabinet can be drilled using a suitable drill bit. Make sure you place the cable entry in a location that will not prevent the cable from being blocked or restricted by any internal components.

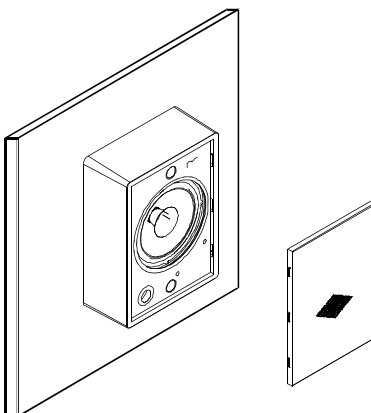

3. Connect the speaker cable into the 3 way terminal block located on the cabinet. Select your required tapping. Fix the speaker cabinet to the wall using suitable fixings (not provided).

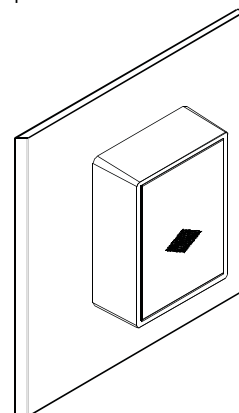

4. Fit the front grill by aligning it with the cabinet and simply push it into place.



Penton UK Ltd

Unit 2 Teville Industrials | Dominion Way | Worthing | West Sussex | BN14 8NW
T: +44 (0)1903 215315 | F: +44(0)1903 215415 | E: sales@pentonuk.co.uk

www.pentonuk.co.uk

JANUARY 2013



RoHS

