

# MOULDED CABINET LOUDSPEAKERS

- **PMC4T/EN**
- **PMC4T/ENC**

EN54-24



## INSTALLATION INSTRUCTIONS

EN54-24:2008

Certificate No: 0359-CPR-00286 TYPE A

1. LOUDSPEAKER ENCLOSURE
2. REFERENCE AXIS
3. HORIZONTAL PLANE
4. REFERENCE PLANE

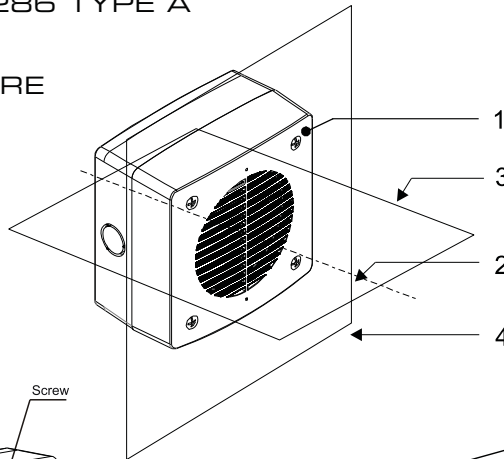

### Circuit Diagram

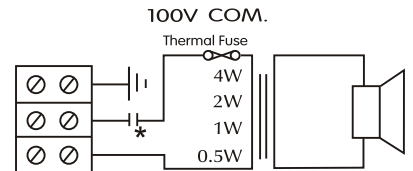

### PMC4T/ENC

\*with capacitor

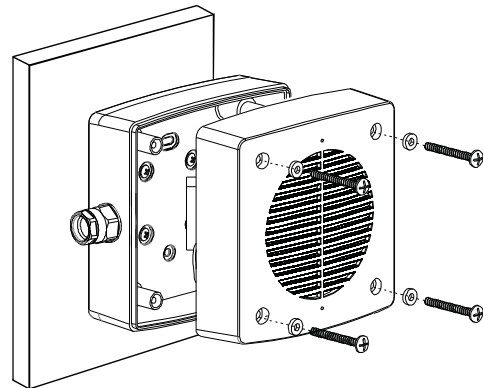
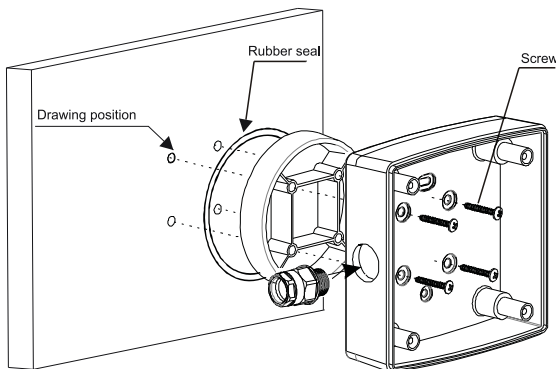

#### ➤ STEP 1

Select a suitable position to mount the loudspeaker. Offer the speaker to the wall or ceiling and mark through the mounting holes to position the fixing points to be drilled. Use a spirit level to ensure that the speaker will be level when fixed. Drill 4 fixing holes as shown in the diagram. Ensure you use the fixing holes that sit inside the rubber seal. The speaker can also be mounted to a standard single gang or BESA type back box. Use suitable raw plugs to secure the fixings.

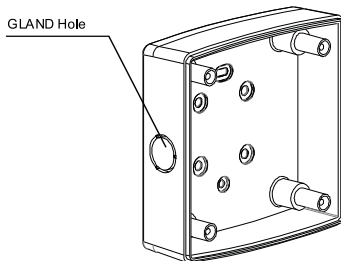

#### ➤ STEP 2

Before fixing the speaker ensure it is correctly orientated to take the incoming speaker cable. The speaker can now be positioned over the fixing holes made in the mounting surface at Step 1. Ensure that the rubber "O" ring gasket and spacer ring is fitted as shown in Step 1. Then use suitable fixings to hold the speaker securely to the surface.

#### ➤ STEP 3

Terminate the speaker cabling into the terminal block via suitable cable glands. Select the correct tapping on the transformer located on the speaker front panel. Then fit the front panel to the back box making sure that the gasket is fitted correctly.

#### ➤ STEP 4

Once the speaker front panel has been fitted to the back box use the 4 screw fixings and washers supplied to secure the front panel. The speaker installation is now complete.



### Penton UK Ltd

Unit 2 Teville Industrials | Dominion Way | Worthing | West Sussex | BN14 8NW  
T: +44 (0)1903 215315 | F: +44(0)1903 215415 | E: sales@pentonuk.co.uk

[www.pentonuk.co.uk](http://www.pentonuk.co.uk)

OCTOBER 2014



RoHS

