

## METAL COLUMN LOUDSPEAKER

➤ **MCS20T/EN**  
➤ **MCS20T/ENC**



## INSTALLATION INSTRUCTIONS

EN54-24:2008

Certificate No:

0359-CPD-0165 TYPE B

1. LOUDSPEAKER ENCLOSURE
2. REFERENCE AXIS
3. REFERENCE PLANE
4. HORIZONTAL PLANE

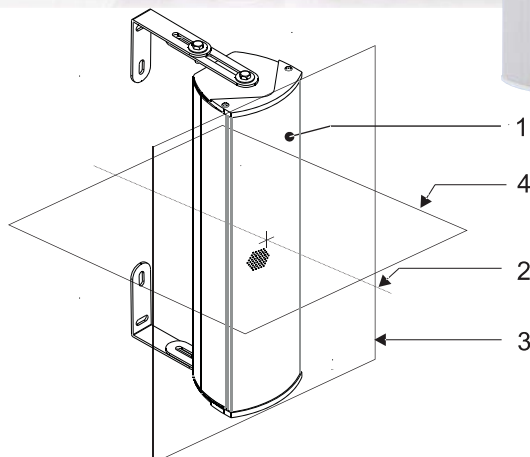

### Circuit Diagram

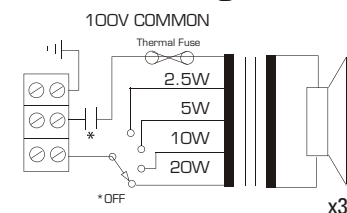
➤ **MCS20T/EN**➤ **MCS20T/ENC**

\* with capacitor

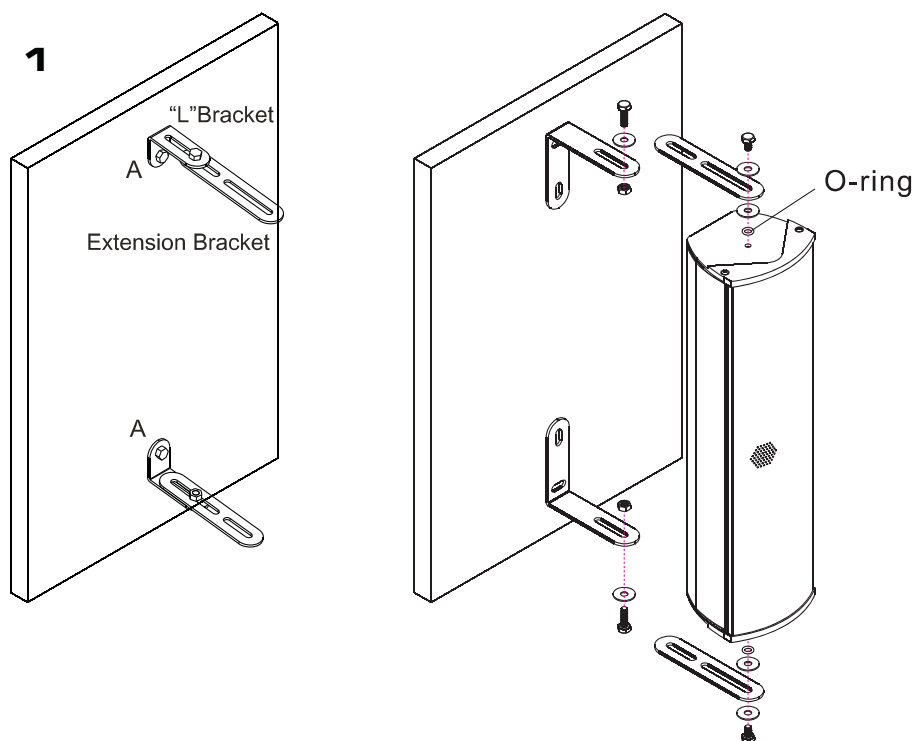

**1.** Mount the top & bottom "L" brackets by drawing a vertical line onto the wall. Each "L" bracket has an outer and inner mounting hole aligned vertically. The centre of the outer holes are 349mm apart and the inner holes are 250mm apart. Mark these positions at the required mounting height on to the vertical line. Align both brackets and double check the fixing points. Fix both brackets securely using suitable fixings (Not supplied). The "L" brackets are supplied with extender plates which can be used at the top to aim the speaker downwards or both top and bottom to mount the speaker further away from the wall. The extender plates are supplied with the speaker as a kit with the "L" brackets and hardware.

**2.** Remove the top cover from the speaker, this is located close to the cable entry. The installation cable can be fitted via a suitably rated gland into the 1 x 20mm gland entry provided.

**3.** The cable can then be terminated into the terminal block located just below the top cover. The terminals are suitable to take "loop in" "loop out" connections up to 2.5mm per core.

**4.** Re-fit the rear cover ensuring that the gasket is in place and that the screw fittings are fitted with their rubber washers to ensure the top cover retains its weatherproof rating.

**5.** Mount the speaker to the "U" bracket using the M10 bolts provided at the top & bottom of the speaker. Position the speaker to the desired angle then tighten the fixings to secure in place.

**6.** The tapping can be adjusted via a recessed selector located at the bottom of the speaker. Use a flat bladed screw driver and insert it into the hole. Rotate the screw driver to select the desired tapping. See the label for tapping details.

2-6

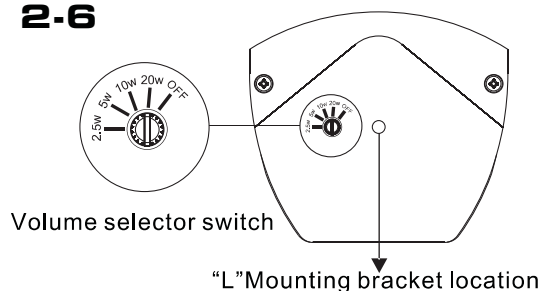

Top View of  
Column Loudspeaker  
with lid off

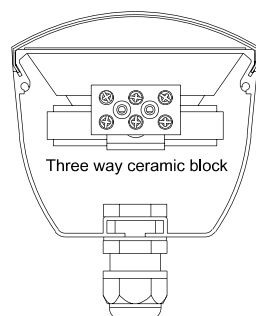

### Penton UK Ltd

Unit 2 Teville Industrials | Dominion Way | Worthing | West Sussex | BN14 8NW

T: +44 (0)1903 215315 | F: +44(0)1903 215415 | E: sales@pentonuk.co.uk

[www.pentonuk.co.uk](http://www.pentonuk.co.uk)

OCTOBER 2012



RoHS

